

# FCS-N1/2A4-NA/D100

## Flow Monitoring – Immersion Sensor without Integrated Processor

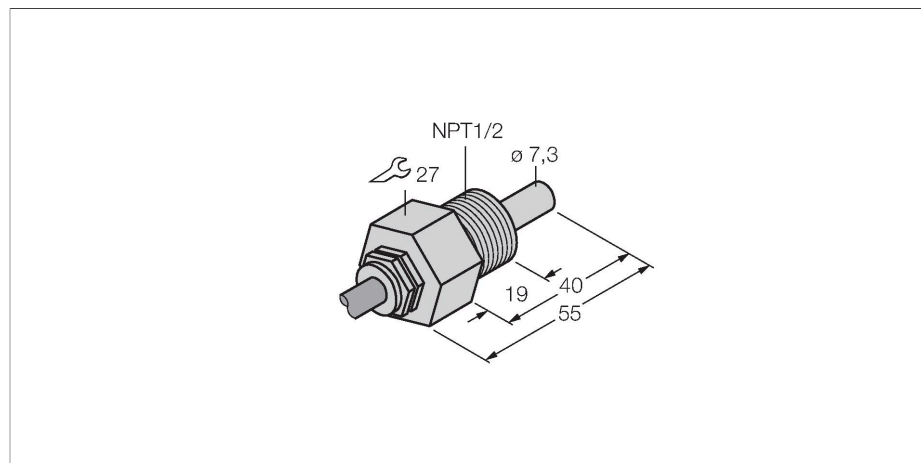

### Features

- Sensor for liquid media
- Calorimetric functionality
- Adjustment via signal processor
- Status indicated via LED chain on signal processor
- Temperature range: +10...+120 °C (up to +135 °C for a short period)
- Cable device
- 4-wire connection to the processor

### Wiring diagram

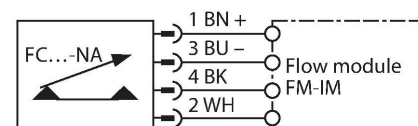

### Functional principle

Our insertion - flow sensors operate on the principle of thermodynamics. The measuring probe is heated by several °C as against the flow medium. When fluid moves along the probe, the heat generated in the probe is dissipated. The resulting temperature is measured and compared to the medium temperature. The flow status of every medium can be derived from the evaluated temperature difference. Thus TURCK's wear-free flow sensors reliably monitor the flow of gaseous and liquid media.

### Technical data

ID no.	6871412
Type	FCS-N1/2A4-NA/D100
Special version	D100 corresponds to: temperature range 10...120 °C
<b>Mounting</b>	<b>Immersion sensor</b>
Water Operating Range	1...150 cm/s
Oil Operating Range	3...300 cm/s
Stand-by time	typ. 8 s (2...15 s)
Switch-on time	typ. 2 s (1...13 s)
Switch-off time	typ. 2 s (1...15 s)
Temperature jump, response time	max. 12 s
Temperature gradient	≤ 250 K/min
Medium temperature	10...+120 °C
Protection class	IP68
Design	Immersion
<b>Housing material</b>	<b>Stainless steel, 1.4571 (AISI 316Ti)</b>
Sensor material	Stainless steel, 1.4571 (AISI 316Ti)
Max. tightening torque of housing nut	30 Nm
Electrical connection	Cable
Cable length (L)	2 m
Cable Jacket Material	FEP
Core cross-section	4 x 0.25 mm <sup>2</sup>
Process Pressure	100 bar

## Technical data

Process connection

1/2" NPT

---