

FCI-N3/4D20A4P-ARX-H1140

Flow Monitoring – Inline Sensor with Integrated Processor

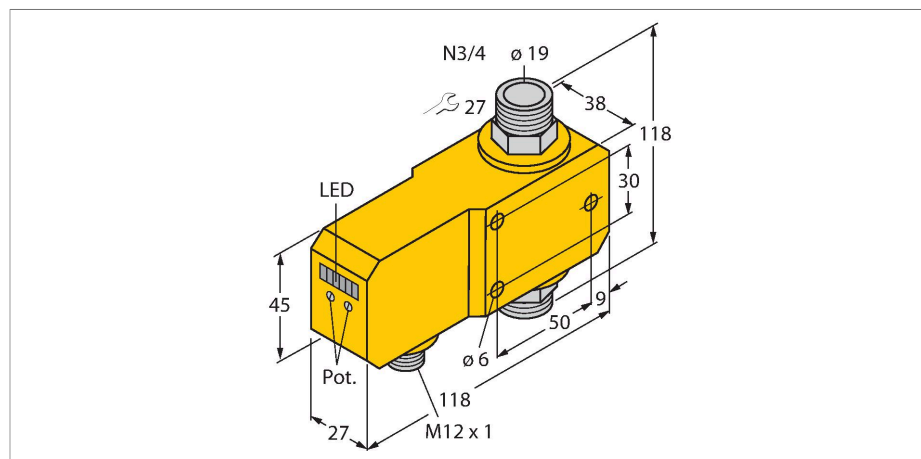

Features

- Flow sensor for liquid media
- Calorimetric principle
- Adjustment via potentiometer
- LED band
- Operating range 4...30 l/min
- DC 4-wire, 21.6...26.4 VDC
- NO contact, relay output
- Plug-in device, M12 x 1

Wiring diagram

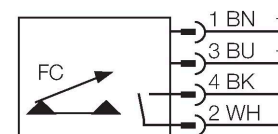

Technical data

ID no.	6870677
Type	FCI-N3/4D20A4P-ARX-H1140
Mounting	Inline sensor
Flow operating range	4...30 l/min
Stand-by time	5...15 s
Switch-on time	0.5...1 s
Switch-off time	0.5...1 s
Temperature gradient	≤ 400 K/min
Medium temperature	0...+80 °C
Ambient temperature	0...+60 °C
Operating voltage	21.6...26.4 VDC
Current consumption	≤ 50 mA
Output function	Relay output, NO contact
Rated operational current	1 A
Short-circuit protection	no
Reverse polarity protection	yes
AC switching voltage	30 VAC
DC switching voltage	36 VDC
Protection class	IP67
Design	Inline
Housing material	Plastic, PBT
Sensor material	Stainless steel, 1.4571 (AISI 316Ti)
Max. tightening torque of housing nut	30 Nm
Electrical connection	Connector, M12 × 1

Functional principle

The function of the inline flow sensors is based on the thermo-dynamic principle. Heat is generated in a measuring tube and absorbed by the flowing medium. The transported heat loss is thus a measure of the flow speed. Thus TURCK's wear-free flow sensors reliably monitor the flow of gaseous and liquid media. A low pressure drop and fast response to flow rate variations are the outstanding features of these devices.

Technical data

Process Pressure	20 bar
Process connection	3/4" NPT
Switching state	LED chain, Green/Yellow/Red
Flow state display	LED chain
Indication: Drop below setpoint	LED red
Indication: Setpoint reached	LED yellow
Indication: Setpoint exceeded	4 x LEDs green