

FEMALE END VIEW

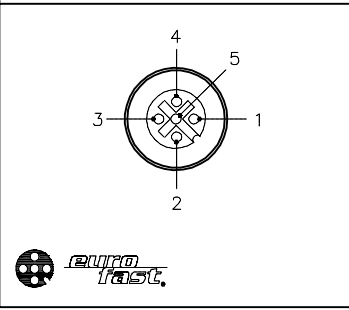

SPECIFICATIONS

|                               |  |
|-------------------------------|--|
| NUMBER OF CONDUCTORS [AWG]    | 3x18 AWG, 16x22 AWG  |
| DRAIN/SHIELD                  | 20 AWG/ALUMINUM-POLYESTER FOIL   |
| CONDUCTOR INSULATION MATERIAL | PVC  |
| OUTER JACKET MATERIAL/COLOR   | TPU/YELLOW   |
| HOUSING MATERIAL/COLOR        | NYLON/BLACK  |
| RECEPTACLE MATERIAL/PLATING   | BRASS/NICKEL   |
| CONTACT CARRIER MATERIAL      | NYLON  |
| CONTACT MATERIAL/PLATING      | BRASS/GOLD   |
| O-RING MATERIAL               | FKM/FPM  |
| OPERATING VOLTAGE [V]         | 10-30 VDC  |
| OPERATING CURRENT [A]         | 4.0 AMPS/SIGNAL, 12.0 AMPS TOTAL   |
| PROTECTION CLASS              | IP68, IP69K: ONLY WHEN ALL RECEPTACLES ARE COVERED WITH PLUGS OR CONNECTED |
| OPERATING TEMPERATURE         | -40°C to +85°C (-40°F to +185°F)   |

WIRING DIAGRAM

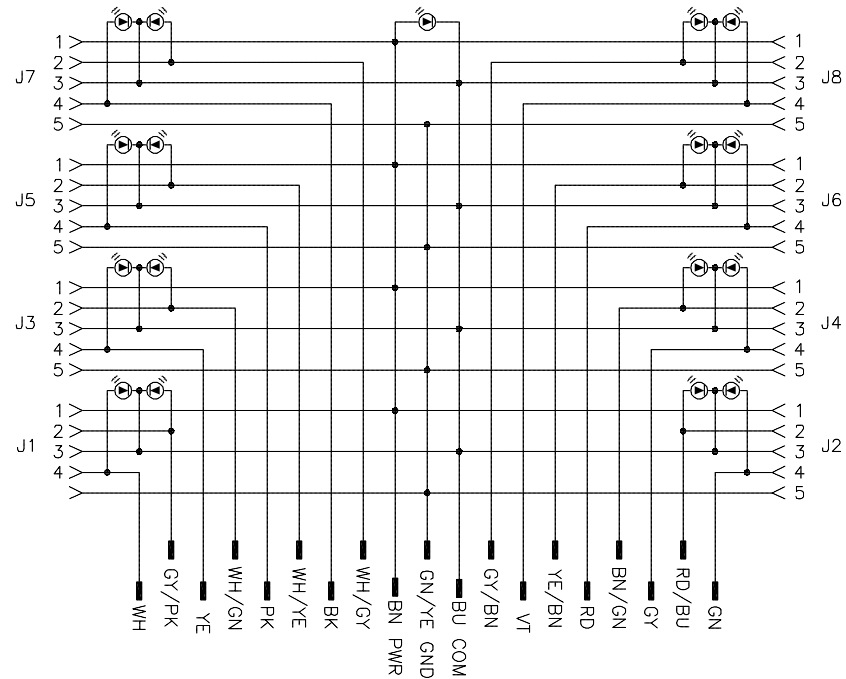

| CABLE LENGTH | TOLERANCE*  |
|--------------|---|
| ALL LENGTHS  | + 4% (OR 50mm) OF LENGTH<br>- 0% (OR 0mm) OF LENGTH<br>WHICHEVER IS GREATER |
| STRIP LENGTH | TOLERANCE*  |
| 0-7mm        | ±0.5mm  |
| 8-29mm       | ±1.0mm  |
| 30-49mm      | ±2.0mm  |
| 50-69mm      | ±3.0mm  |
| 70-100mm     | ±4.0mm  |
| OVER 100mm   | ±5.0mm  |

\* UNLESS OTHERWISE SPECIFIED

\* METERS SEE NOTE 1

- NOTES:
- "\*" INDICATES CABLE LENGTHS IN METERS. CONTACT TURCK TO ORDER SPECIFIC LENGTH.
  - "/S90" DESIGNATES THERMOPLASTIC POLYURETHANE (TPU) CABLE JACKET.

SOURCE DRAWING - FOR REFERENCE ONLY

|   |   |  |                              |  |              |
|---|---|--|------------------------------|--|--------------|
| RELATED DOCUMENTS<br>1.<br>2.<br>3.<br>4. | 3RD ANGLE PROJECTION<br>  | THIS DRAWING IS CONFIDENTIAL AND THE PROPERTY OF TURCK INC. USE OF THIS DOCUMENT WITHOUT WRITTEN PERMISSION IS PROHIBITED. |                              | 3000 CAMPUS DRIVE<br>MINNEAPOLIS, MN 55441<br>1-800-544-7769<br>(763) 553-7300<br>(763) 553-0708 fax<br>www.turck.us |              |
|   | MATERIAL<br>SEE SPECIFICATIONS                                  | DRFT RWC<br>APVD   | DATE 09/03/04<br>SCALE 1=2.7 | DESCRIPTION<br>8MB12Z-5P3-*/S90  |              |
| FINISH<br>SEE SPECIFICATIONS              | ALL DIMENSIONS DISPLAYED ON THIS DRAWING ARE FOR REFERENCE ONLY | UNIT OF MEASUREMENT<br><b>MILLIMETER [ INCH ]</b>  |                              | IDENTIFICATION NO.   | REV<br>K     |
| K ADD CE SYMBOL TO LABEL                  | NF 08/30/18 66305   | DO NOT SCALE THIS DRAWING  |                              | FILE: 777005432  | SHEET 1 OF 1 |
| REV DESCRIPTION                           | BY DATE ECO NO.   |  |                              |  |              |