

FEMALE END VIEW

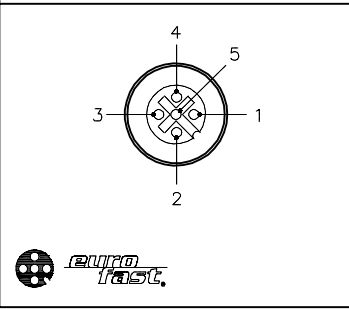

SPECIFICATIONS

|                               |  |
|-------------------------------|--|
| NUMBER OF CONDUCTORS [AWG]    | 3x18 AWG, 8x22 AWG   |
| CONDUCTOR INSULATION MATERIAL | POLYESTER ELASTOMER  |
| OUTER JACKET MATERIAL/COLOR   | TPE/YELLOW   |
| HOUSING MATERIAL/COLOR        | NYLON/BLACK  |
| RECEPTACLE MATERIAL/PLATING   | BRASS/NICKEL   |
| CONTACT CARRIER MATERIAL      | NYLON  |
| CONTACT MATERIAL/PLATING      | BRASS/GOLD   |
| O-RING MATERIAL               | FKM/FPM  |
| OPERATING VOLTAGE [V]         | 10-30 VDC  |
| OPERATING CURRENT [A]         | 4.0 AMPS/SIGNAL, 12.0 AMPS TOTAL   |
| PROTECTION CLASS              | IP68, IP69K: ONLY WHEN ALL RECEPTACLES ARE COVERED WITH PLUGS OR CONNECTED |
| OPERATING TEMPERATURE         | -40°C to +85°C (-40°F to +185°F)   |

WIRING DIAGRAM

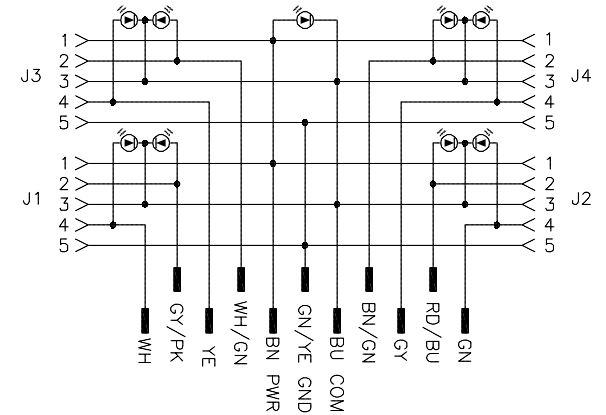

| CABLE LENGTH | TOLERANCE*  |
|--------------|---|
| ALL LENGTHS  | + 4% (OR 50mm) OF LENGTH<br>- 0% (OR 0mm) OF LENGTH<br>WHICHEVER IS GREATER |
| STRIP LENGTH | TOLERANCE*  |
| 0-7mm        | ±0.5mm  |
| 8-29mm       | ±1.0mm  |
| 30-49mm      | ±2.0mm  |
| 50-69mm      | ±3.0mm  |
| 70-100mm     | ±4.0mm  |
| OVER 100mm   | ±5.0mm  |

\* UNLESS OTHERWISE SPECIFIED

\* METERS  
SEE NOTE 1

- NOTES:
- "\*" INDICATES CABLE LENGTHS IN METERS. CONTACT TURCK TO ORDER SPECIFIC LENGTH.
  - "/S101" DESIGNATES, FLEXLIFE-20 CABLE.

SOURCE DRAWING - FOR REFERENCE ONLY

|                    |   |  |     |  |          |
|--------------------|---|--|-----|--|----------|
| RELATED DOCUMENTS  | 3RD ANGLE PROJECTION  | THIS DRAWING IS CONFIDENTIAL AND THE PROPERTY OF TURCK INC. USE OF THIS DOCUMENT WITHOUT WRITTEN PERMISSION IS PROHIBITED. |     | 3000 CAMPUS DRIVE<br>MINNEAPOLIS, MN 55441<br>1-800-544-7769<br>(763) 553-7300<br>(763) 553-0708 fax<br>www.turck.us |          |
| 1.                 |   | DRFT   | RWC | DATE   | 10/08/04 |
| 2.                 |   | APVD   |     | SCALE  | 1=2.0    |
| 3.                 | ALL DIMENSIONS DISPLAYED ON THIS DRAWING ARE FOR REFERENCE ONLY | UNIT OF MEASUREMENT  |     | DESCRIPTION  |          |
| 4.                 |   | MILLIMETER [ INCH ]  |     | 4MB12Z-5P3-*/S101  |          |
| MATERIAL           | CONTACT TURCK FOR MORE INFORMATION                              | IDENTIFICATION NO.   |     | REV  |          |
| SEE SPECIFICATIONS |   |  |     | L  |          |
| FINISH             | DO NOT SCALE THIS DRAWING                                       | FILE: 777003267  |     | SHEET 1 OF 1   |          |
| SEE SPECIFICATIONS |   |  |     |  |          |

|     |                        |    |          |         |
|-----|------------------------|----|----------|---------|
| L   | ADD CE SYMBOL TO LABEL | NF | 08/30/18 | 66305   |
| REV | DESCRIPTION            | BY | DATE     | ECO NO. |