

FEMALE END VIEW

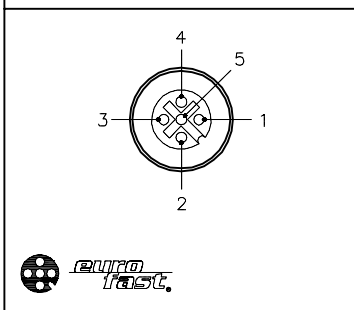

SPECIFICATIONS

|                               |  |
|-------------------------------|--|
| NUMBER OF CONDUCTORS [AWG]    | 3x18 AWG, 8x22 AWG   |
| DRAIN/SHIELD                  | 22 AWG/ALUMINUM-POLYESTER FOIL   |
| CONDUCTOR INSULATION MATERIAL | PVC  |
| OUTER JACKET MATERIAL/COLOR   | PVC/YELLOW   |
| HOUSING MATERIAL/COLOR        | NYLON/BLACK  |
| RECEPTACLE MATERIAL/PLATING   | BRASS/NICKEL   |
| CONTACT CARRIER MATERIAL      | NYLON  |
| CONTACT MATERIAL/PLATING      | BRASS/GOLD   |
| O-RING MATERIAL               | FKM/FPM  |
| OPERATING VOLTAGE [V]         | 10-30 VDC  |
| OPERATING CURRENT [A]         | 2.0 AMPS/SIGNAL, 9.0 AMPS TOTAL  |
| PROTECTION CLASS              | IP68, IP69K: ONLY WHEN ALL RECEPTACLES ARE COVERED WITH PLUGS OR CONNECTED |
| OPERATING TEMPERATURE         | -40°C to +85°C (-40°F to +185°F)   |

WIRING DIAGRAM

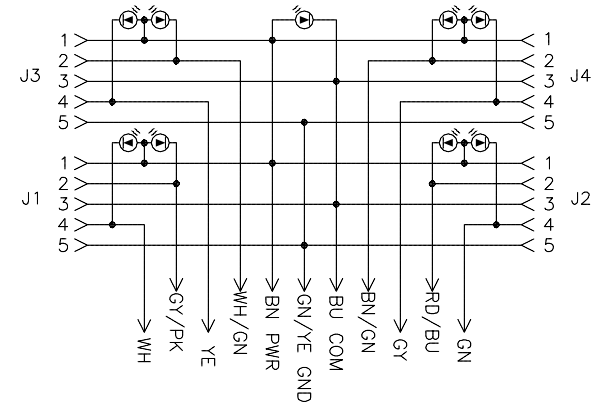

| CABLE LENGTH | TOLERANCE*  |
|--------------|---|
| ALL LENGTHS  | + 4% (OR 50mm) OF LENGTH<br>- 0% (OR 0mm) OF LENGTH<br>WHICHEVER IS GREATER |
| STRIP LENGTH | TOLERANCE*  |
| 0-7mm        | ±0.5mm  |
| 8-29mm       | ±1.0mm  |
| 30-49mm      | ±2.0mm  |
| 50-69mm      | ±3.0mm  |
| 70-100mm     | ±4.0mm  |
| OVER 100mm   | ±5.0mm  |

\* UNLESS OTHERWISE SPECIFIED

NOTES:  
1. "\*" INDICATES CABLE LENGTHS IN METERS. CONTACT TURCK TO ORDER SPECIFIC LENGTH.

SOURCE DRAWING - FOR REFERENCE ONLY

|   |   |  |   |  |                           |
|---|---|--|---|--|---------------------------|
| RELATED DOCUMENTS<br>1.<br>2.<br>3.<br>4. | 3RD ANGLE PROJECTION<br>  | THIS DRAWING IS CONFIDENTIAL AND THE PROPERTY OF TURCK INC. USE OF THIS DOCUMENT WITHOUT WRITTEN PERMISSION IS PROHIBITED. |   | 3000 CAMPUS DRIVE<br>MINNEAPOLIS, MN 55441<br>1-800-544-7769<br>(763) 553-7300<br>(763) 553-0708 fax<br>www.turck.us |                           |
|   |   | DRFT   | RWC   | DATE   | 10/08/04                  |
| MATERIAL<br>SEE SPECIFICATIONS            | ALL DIMENSIONS DISPLAYED ON THIS DRAWING ARE FOR REFERENCE ONLY | APVD   |   | SCALE  | 1=2.0                     |
| FINISH<br>SEE SPECIFICATIONS              |   | CONTACT TURCK FOR MORE INFORMATION   | UNIT OF MEASUREMENT<br><b>MILLIMETER [ INCH ]</b> |  | IDENTIFICATION NO.        |
| J   | ADDED CE MARK TO LABEL  | ER   | 08/30/18  | 66305  |                           |
| REV                                       | DESCRIPTION   | BY   | DATE  | ECO NO.  | DO NOT SCALE THIS DRAWING |
|   |   |  |   |  | FILE: 777005442           |
|   |   |  |   |  | SHEET 1 OF 1              |